

- Easy installation - Tank or Wall Mount
- Tamper proof locked enclosure
- Optional TEFC (Totally Enclosed Fan Cooled Motor) for 24/7 operation.
- Low power requirements
- Self priming pump head



The Ecolo AEP System, combined with our effective odor specific AirSolutions is the most effective method for eliminating odors in a broad range of industrial and environmental applications.

AEP System - Odor counteractant delivery system

The all new AEP system is part of the AirStreme line of products by Ecolo. The AEP is tried, tested and proven and is installed in over thousands of industrial type facilities around the world today.

All components are securely enclosed in a weather, corrosion resistant enclosure enabling the control module to be located away from the treatment area. Each system incorporates a selector switch with continuous run, off, or cycle timer modes. This combination of programmability and versatility equate to a very simplistic yet versatile and easy-to-operate system.

The AEP Systems along with Ecolo AirSolution is ideal for neutralizing odors in:

- Transfer Stations
- Composting Plants
- Large Industrial Projects
- Processing Plants
- Landfill Sites
- Wastewater
- Exhaust Stacks
- Other Odorous Applications

Features of the NEW AEP System

- Integrated Controller Design - pump and programmable controller in one clean polished system
- Surge protection
- Advanced Programming Capabilities - Event Timer, Repeat Cycle, Everyday, Individual Day, Weekday/Weekend
- Digital Display with Touch Pad Programming and Indicator Lights for Accessories - Rain, Wind, Tank Level, Auto Run, Alarm Pump, Tank Mixer
- Adaptive Microprocessor with Real Time Clock
- Internal Battery back up
- Password protection
- Data Collection Capabilities: Runtime, Pump Hours, Daily Peak Temperature, Daily Peak Current
- Board mounted RF (radio frequency) receiver - extended range

Optional Accessories for the AEP:



Rain Sensor



Wind Sensor

Standard Install Configuration

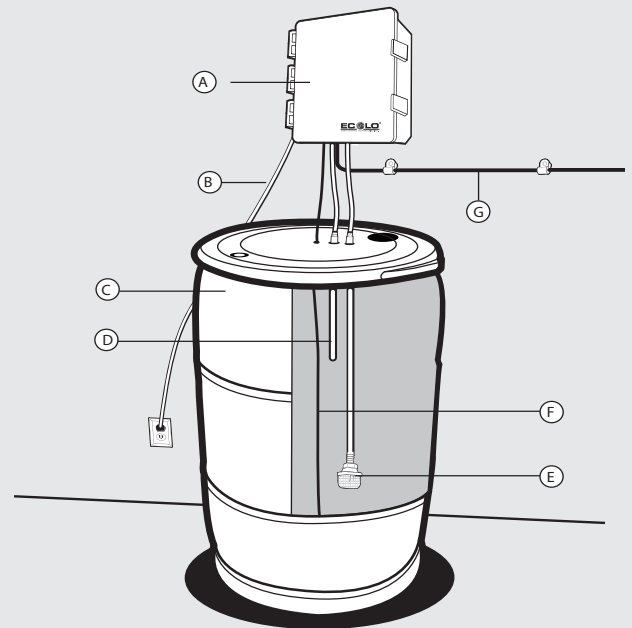

PART	DESCRIPTION
A	AEP Controller
B	Power Cord
C	55 Gallon Drum
D	Return Line
E	Strainer
F	Tank Level Sensor
G	Discharge Line

Integrated Controller Design

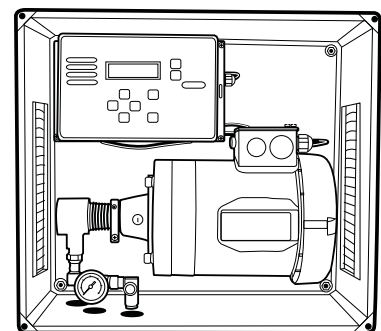

DUTY	HP	HZ	MAX AMB TEMP	V
Cont	1/2	60	40° C / 110° F	110/120

Ecolo Odor Control Technologies

59 Penn Drive, Toronto, ON,
Canada, M9L 2A6
(800) NO SMELL | (416) 740.3900
info@ecolo.com | www.ecolo.com



REV050911